

CVC240HXL Series Installation and Operation Guide

Please read this guide carefully before use and keep it for future reference. Remember to complete and mail the owner registration form. (Installer - Please give this manual to the user of this product after your use.)

Table of Contents

TABLE OF CONTENTS	2
GENERAL INFORMATION.....	3
INTRODUCTION	3
IMPORTANT INFORMATION	3
CERTIFICATES OF COMPLIANCE	3
WARNINGS AND CAUTIONS	4
PACKAGE CONTENTS / PARTS LIST	5
DESCRIPTION.....	6
PRODUCT OVERVIEW	6
FEATURES	6
SPECIFICATIONS.....	6
INSTALLATION INSTRUCTIONS	7
WIRING DIAGRAM	7
CAMERA INSTALLATION	7
CABLE INSTALLATION	8
CONNECTOR ALIGNMENT	9
HIROSE ALIGNMENT	9
XL (MIL SPEC) ALIGNMENT	9
IMAGE ORIENTATION.....	10
ORIENTATION REQUIREMENTS	10
HOW TO CHANGE YOUR IMAGE.....	10
TROUBLESHOOTING AND MAINTENANCE.....	11
TROUBLESHOOTING	11
PREVENTATIVE MAINTENANCE	11
HOW TO GET SERVICE.....	12
ADDITIONAL INFORMATION.....	13
WARRANTY	13
INTEC OFFICES.....	13
OWNER REGISTRATION.....	14

General Information

Introduction

Thank you for selecting an INTEC Car Vision® System. Before using your system, please be sure to read and understand these instructions carefully. If you have any questions or concerns, please do not hesitate to contact us toll free at 800-468-3254 (west) or 800-522-5989 (east).

This Guide is intended to provide you with information needed to successfully install and operate the CVC240HXL camera.

Important Information

Please read, follow and keep these instructions for future reference. A copy of these instructions should be left in the vehicle in which the system is installed.

There are no user serviceable parts inside the system components. All service must be completed by authorized service personnel only. Please refer to the Warranty section described later in this manual.

Always use the proper tools, wear protective clothing and take necessary precautions when working around electricity to prevent electrical shock.

Use only INTEC specified and provided cables to connect the components of the system. Use of other than INTEC specified and supplied components and cabling could be dangerous and result in damage to the system components and void the warranty.

Use only INTEC specified and supplied accessories and options when upgrading your system.

Operating the camera system on too low or too high a voltage may damage the system.

Always confirm the view provided by the camera is adequate for your needs prior to vehicle use. Adjustments to the camera viewing angle should be made before use, if necessary.

Most states have laws pertaining to motor vehicles equipped with a video display within the driver's field of vision, either directly or indirectly, unless the video display is used in conjunction with a back up safety camera to monitor the blind spots around the vehicle. INTEC's products are specifically designed to enhance vehicle safety. Use of an INTEC display to view video in any manner other than intended requires installation in accordance with your state laws.

We recommend the use of the optional Radar Sensors to enhance overall safety.

Do NOT let the Car Vision® System distract you from driving safely.

Certificates of Compliance



This device complies with Part 15 of the FCC rules.

Warnings and Cautions

Warnings



Do NOT attempt to connect other electrical devices to the power wire harness of the Car Vision® System as this can cause an over current situation which can lead to electrical shock or fire.



If at any time you see or smell smoke coming from the Car Vision® System, stop driving, exit the vehicle and disconnect main power. Check the system and remove any damaged components before you resume normal vehicle operation.



Do NOT attach the wiring to any moving parts, across sharp edges or close to heat sources as this may cause shorting of the wires and may lead to a fire or electrical shock.



When installing the camera system be certain that all items are secure. Items that are not secure or mounted in an unstable manner can come loose and cause damage or personal injury.



When installing the system be sure to use only INTEC supplied brackets. The Car Vision® camera must be insulated from the vehicle body. The supplied camera bracket provides the required insulation. Failure to do so could result in a fire and lead to property damage or personal injury.



Do NOT install the camera in any area that allows it to extend out past the vehicle as this can cause injury if it were to come in contact with people walking around the vehicle.



Never use fuses of a larger rating than those supplied with your Car Vision® System. Use of larger rated fuses can cause excessive current through the system if a short occurs and could lead to a fire.

Cautions



Confirm that the orientation of the image on the display is proper. Rear facing cameras should yield a mirror image, where items on the left of the vehicle appear on the left side of the monitor.



Before you begin driving, be sure the display controls are adjusted properly. This will avoid unnecessary distractions while driving.



Do NOT attempt to open or service your equipment. Removal of the product enclosure can lead to electrical shock.



You should not attempt to make any adjustments to the Car Vision® System while driving as this can lead to an accident. Only make adjustments when the vehicle is stopped.



Keep the Car Vision® System clean and free from dirt, snow and ice. If the camera glass or display panel becomes dirty, clean them before use. If they are covered with snow and/or ice, it should be cleared off before use. Failure to do so could lead to an accident.



When running a cable from the exterior to the interior of a vehicle, care needs to be taken to seal the entry point. Failure to do so could allow in exhaust fumes, other toxic gases or water.

Package Contents / Parts List

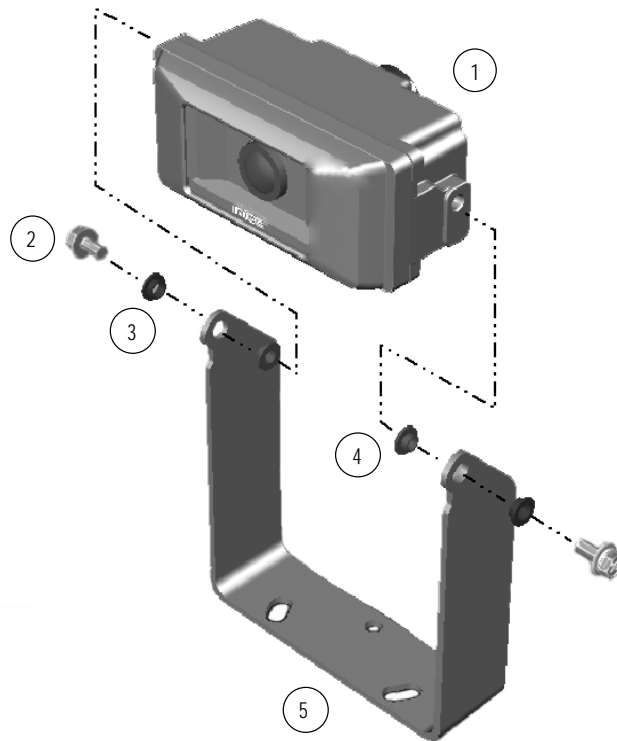

- 1 – CVC240HXL or CVC240SHXL (includes all items shown)
- 2 – Camera Mounting Bolt Set, Part# CV230CBFB
- 3 – Bracket Bushing B, Part# CV230CBBB
- 4 – Bracket Bushing A, Part# CV230CBBA
- 5 – Camera Mounting Bracket, Part# CV240CBXL
- 6 – Bracket Mounting Bolt Set, (Not Shown)

Description

Product Overview

The CVC240HXL camera is designed to be waterproof and is rated to IP68 against water intrusion. It has also been designed to operate in a variety of mobile applications.

Features

- Watertight Military Spec Connector ensures complete moisture protection.
- Widest Field of View provides operator maximum visibility for faster response to hazards.
- Extreme Low Light Sensitivity for excellent visibility, day or night.
- Standard thermostatically controlled heater feature helps melt away snow, ice and frost away from the camera and allow cold weather operation
- Eight Year Warranty covers this heavy-duty extended life camera.
- Optional Automatic Shutter protects lens from dirt and dust when not in use.

Specifications

Pick Up Element: 1/3" CCD

Pixel Count: 510 (H) x 492 (V)
(250,920 total pixels)

Lens: 2.0mm f2.0 auto iris

Minimum Illumination: 0.05 lux
(0.005 ft candles)

Resolution: 380+ lines (H) x 350+ lines (V)

Field of View: 125° (H) x 100° (V)

Shock and Vibration: 9G @ 0-2000 cpm

Weight: 0.5 lbs.

Dimensions: (with mounting bracket)
W 4.45" x H 4.87" x D 2.29"
(without mounting bracket)
W 3.70" x H 1.58" x D 2.29"

Operating Conditions: All weather Operation

Color: Metallic Silver

Options: Shutter, Chrome Housing

Warranty: Eight years parts & labor. Extended warranty available at time of purchase.

Installation Instructions

Your Car Vision® System should be installed so the ignition switch or power switch that controls your vehicle's power also provides power to the Car Vision® System. To be in a constant ready state, the Car Vision® System consumes a small amount of power even when it is in Standby mode. Therefore, connecting the system to a pre-ignition constant power source or directly to the battery can drain your vehicle battery.

The Car Vision® System is designed so that the rear mounted Car Vision® camera can have priority over any other camera or data input into the display provided the blue reverse gear power source lead is properly connected and the rear camera is connected to the Camera 1 position. (Please see the Wiring Diagram provided with your controller). When the vehicle is placed in reverse, the rear mounted camera will be activated and the picture it provides will be shown on the display screen. Always confirm proper operation before travel. In multiple camera systems, other camera views can also be triggered automatically within a priority scheme. If you have any questions regarding the proper installation or operation of your Car Vision® System please call INTEC @ 800-468-3254 (west) or 800-522-5989 (east)

Wiring Diagram

(Refer to the Wiring Diagram provided with your controller or see the Wiring Diagram in your monitors operation guide).

Camera Installation

For optimum field of view, mount the rear camera approximately 10 feet up on the vehicle from ground level so that the rear-most part of the vehicle is visible at the bottom of the display screen. If this is not possible, mount the camera in a fashion that will give the driver the best possible view of the area behind the vehicle while still aligning the rear-most part of the vehicle with the bottom of the display screen as a reference.

1. Establish a solid mounting location in the center of the vehicle using the guidelines above. Make sure that no part of the installation obstructs any lights or any part of the driver's view.

2. Position the camera(s) with the mounting bracket attached in the location where it will be mounted and turn on the system to check the field of view (you may have to reverse the camera's mounting bracket

to obtain the proper angle). Be certain the field of view of all installed cameras provides adequate and appropriate coverage for your application.

3. Once the location and angle have been determined, use the camera bracket or bracket extension as a template to mark the position where the holes will be drilled and drill the holes. Make sure the area being drilled into is clear of all wires and other items before you begin drilling.

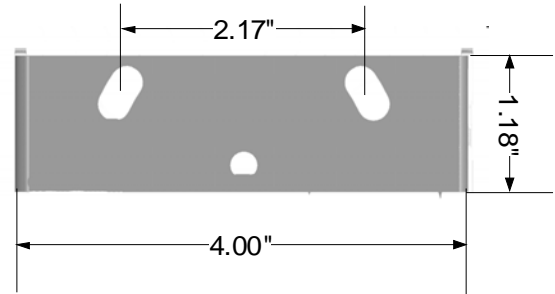

4. Once the holes are drilled, install the camera mounting bracket and extension, if required, with the mounting bolts provided. You may need to purchase additional hardware if the hardware provided does not work in your application.

5. Mount the camera in the bracket with the hardware provided and align it so that the rear-most part of the vehicle is in line and viewable at the bottom of the display screen.

6. It is recommended that you apply an anti-galvanic compound to the camera mounting bolts before installation.

7. The XL connector is a twist to lock type. Simply align the keys on the cable connector with the ones on the camera connector and push in and twist until firmly seated.



Cable Installation

The following are general tips and precautions to keep in mind while routing the cable between the camera and controller or the controller and display. With the exception of Molex connectors (found on the CVU and CVXLP series cable harnesses), the entire cable is weatherproof and can withstand exposure to cold (down to -40 degrees F), rain, snow, dirt, etc. If you feel the environment in which the cable is exposed is extremely harsh, you can route the cable through a conduit or consult INTEC about our optional application cable harnesses for extreme temperature or environmentally challenging applications.

If exposed to the environment, the Molex connectors must be weatherproofed. A simple means is to use 1-inch diameter gum interior heat shrink tubing (available from INTEC) to cover the whole connector assembly. This will seal and protect the connector from direct moisture due to rain, snow, vehicle washing, etc. Weatherproof junction boxes, properly sealed, are another means. One should occasionally check the seals to make sure they remain intact. We recommend using the waterproof XL or H cables and connectors so that heat shrinking is not necessary.

DO NOT use electrical tape, slotted plastic conduit or silicon only as a weatherproofing. They may protect the connector for a short period of time but will quickly lose their ability to keep moisture away from the connector and pins.

Other cable installation hints include:

- 1) Do not attach the cable to moving vehicle parts.
- 2) Keep the cable at least 12 inches away from any significant source of heat.
- 3) Avoid running the cable along the same side of the chassis as the ABS wiring.
- 4) Route the cable where it is protected from road debris or overhead hazards.
- 5) Secure the cable so that vehicle vibration and shock do not loosen it. Tie the cable down approximately every 12 - 18 inches. Insulated P-clamps are recommended where appropriate.
- 6) Secure the cable on both sides of a pivot point allowing enough cable to extend fully but not so much as to cause snagging. Run the cable to avoid getting caught in the pivot point.

7) If you have excess cable, do not coil it too tightly; avoid crimping the cable.

8) Do not staple through the cable.

Periodic checks of the camera system and its wiring will help spot potential trouble areas before they result in a system failure. An excellent time to check is when the vehicle is in for routine maintenance.

Connector Alignment

There are three types of connectors commonly used in the camera system; Molex, Hirose, and Mil Spec. All of which have alignment marks or keys to insure correct alignment and proper installation.

Hirose Alignment

The Hirose panel mounted connector found on the display, controller, and certain cameras has an alignment mark arrow on the face of the connector as shown below. This same mark is found on the face of the inline cable mating jack when multi-part cable extensions are used.

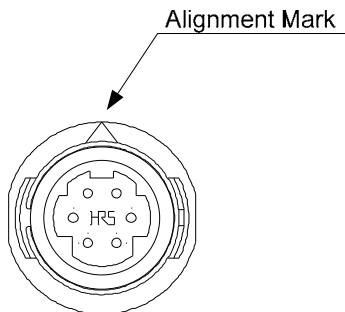

Inline cable jack shown below:

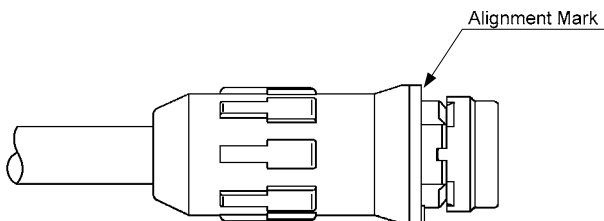

When making a connection, align the arrow on the outer shell of the mating cable connector (seen below) with the alignment mark on the face of the mating connector and push until locked.

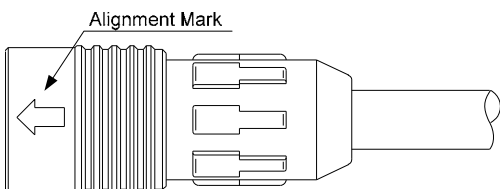

XL (Mil Spec) Alignment

The XL (Mil Spec) panel mounted connector found on certain controllers and cameras has a 5 way keyed alignment as shown below. This same 5 way keyed alignment is found on the face of the inline cable mating jack when multi-part cable extensions are used.

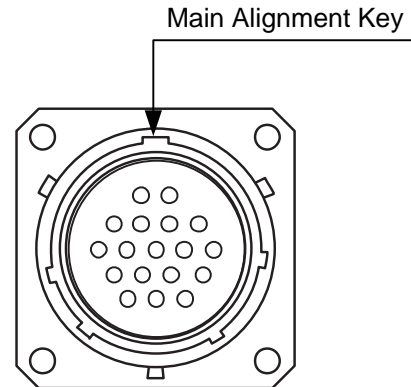

Inline cable jack shown below:

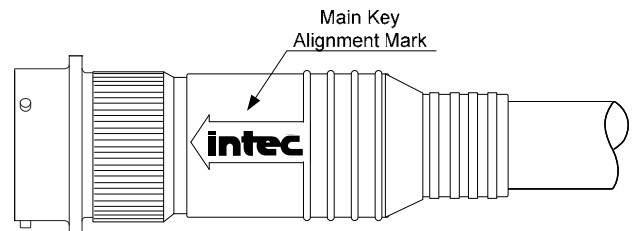

When making a connection, align the 5 keys on the connectors and turn the outer locking ring until locked. For XL cables with over molded back shells the arrow with the INTEC logo is inline with the main (top) alignment key.

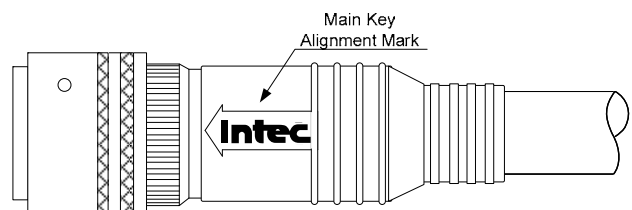
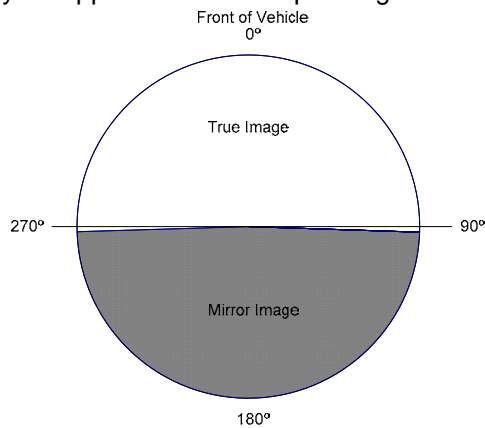

Image Orientation

The orientation of the image displayed is critical to safe vehicle operation. An object on the right side of your vehicle needs to be seen on the right side of the displayed image.

Orientation Requirements

Generally, if your display is facing rearwards, you would want a Mirror image displayed from a camera facing rearward and a True image displayed from a camera facing forward. The image orientation of cameras on the right or left side of a vehicle depends on how far off of center they are facing. For example; a camera mounted on the right side at 90° off of the front would usually require a true image to be displayed. But set the camera to 91° off of the front and a mirror image may be required. Be sure to confirm the image(s) displayed are appropriate for your application before operating the vehicle.



How to Change Your Image

INTEC's CVC Series cameras are set as default at the factory to display a mirror image when used with our CVD or CVM Series displays and monitors. Should you need to change the default image the CVC240HXL is equipped with a switch on the back side of the camera.

If you need to reverse the camera image you can do so by using a flat screwdriver and rotating the image reversal switch on the back of the camera.

The camera is by default set to "T" which when connected to an Intec display will provide a "Mirror" image.

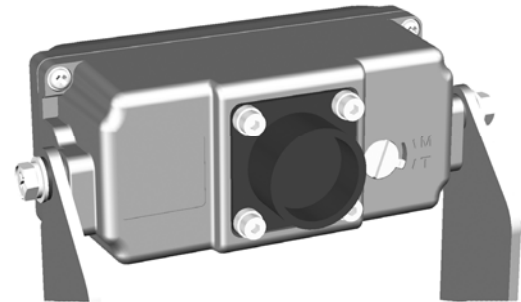

Troubleshooting and Maintenance

Troubleshooting

Display shows a white or blue screen:

Check the cables for obvious damage (i.e. cuts, crimping) and the connectors for corrosion or pin damage. Make sure connectors are securely connected and free of debris.

If spares are available, swap out one item at a time; the camera, controller and associated cabling.

Display doesn't light up – dark screen:

Check the red and black wires at the controller to make sure they are properly connected to the vehicle power and ground. See if proper voltage is reaching the controller.

See if the fuses on the controller are okay. If not, replace with new fuses. The green LED on the controller will be illuminated if the individual power circuit is functioning properly. (See specification section of the controllers operation guide for the proper fuse rating).

Make sure connectors are securely connected and free of debris. Check the cable for obvious damage. There should be no continuity between any of the wires inside the cable. If shorting has occurred, the display and controller should always be returned for service and the cable replaced.

Picture is blurry, out of focus or distorted:

Check the camera and clean any dirt, dust or moisture found on the outside glass lens cover. **If any moisture is visible on the inside of the camera, remove and return the camera to INTEC for service.**

Adjust display controls (i.e. brightness and contrasts) to see if picture clears up.

Check voltage on the red power wire to see if sufficient power is reaching the controller. Low voltage may cause the picture to blur or darken.

My shutter door will not open or close:

Check the camera and clean away any excessive dirt, debris or snow and ice found on the outside of the camera. If the area is clear and the shutter still does not function there may be a problem with the shutter mechanism, the camera cable, or the monitor or controller

I've experienced a short in my system and after correcting it my image is reversed (CVD Series Displays):

After a short, it may be necessary to reset the display software. (Refer to the displays Software Guide on the Installation and Operation CD for instructions on resetting the menu).

A continuous tone is heard through the remote and I have no remote control function (CVD Series Displays)::

Turn the vehicle power off for 10 seconds and turn it back on.

Check to make sure the remote control is connected properly.

Preventative Maintenance

The most effective way of reducing camera system failure is regular preventative maintenance. At least once every two weeks and/or every time the vehicle is in for its scheduled maintenance is recommended.

Although it would be difficult to cover every possible scenario, the following are some examples to look for:

1. Physical damage to the camera. Examples: cracked camera glass, bent front covers, damaged casing or brackets.
2. Dirt or moisture on the camera's glass. Cleaning the camera's glass should be done with a clean, soft cloth to prevent scratching. For excessive dirt build up, you may need to rinse the camera glass with water or glass cleaner first.
3. Scratched camera glass. Excessive scratches on the camera's glass can distort the image. Cameras with scratched glass should be returned to INTEC for service.
4. Moisture behind the camera glass.

If this is found, simply removing the cover and wiping off the glass will not solve the problem. Repairing the source of where the moisture is coming into the camera is the only way to prevent it from happening again. The camera should be returned to INTEC for service.

5. Damage to the cable and the connector seal. This includes the main cable as well as the camera and monitor pigtails. Examples: Cuts or abrasions in the cable, cuts in the connector seal or a connector seal that has come loose.

Note: Connector sealing is not required in the XL and Hirose Camera Series.

6. Dirt on the display. Cleaning the display should be done with a clean, soft cloth to prevent scratching. For excessive dirt build up you can lightly dampen your cloth with water or glass cleaner.

7. Physical damage to the display, remote or controller and its power conductors. Examples: Cracked display casing, missing parts, exposed power wires.

8. Equipment that has come loose. Examples: Cables that are not secure, cameras, displays, and their brackets which may have come loose.

9. Educating the drivers on reporting minor problems before they become major problems. Example: Unreported moisture intrusion can result in the camera being damaged beyond repair.

By taking a few minutes to inspect the camera system on a regular basis you will ensure long-term reliability with minimum cost and down time.

Periodic checks of the camera system components and wiring will help spot potential trouble areas before they result in a system failure. An excellent time to check is each time the vehicle is in for routine maintenance.

How to get Service

If none of the troubleshooting suggestions in this manual solve your problem, you may need to return the product to INTEC for service.

First, call INTEC's Customer Service Department at either our Western Office (800) 468-3254 or our Eastern Office (800) 522-5989.

Explain the problem to the customer service representative. The representative will check to see if you tried the in-field adjustments and may offer alternative solutions for you to try. If these solutions don't work, you may be asked to send some or all of your system to INTEC.

A Return Materials Authorization (RMA) number will be issued. Refer to this number during any future contact with INTEC concerning this service.

Please have the following information available to give to the customer service representative:

1. The product model number and serial number.

2. A description of the problem.

3. The type of vehicle on which the product is installed.

4. Your name, address and phone number.

5. The address, phone number and contact person of where we should return the product after it is repaired if this is different than above.

6. Any special requests (i.e. repair estimates, expedite return shipment).

7. Proof of purchase.

Send the product, prepaid and insured to the closest INTEC office:

Western U.S. and Canada:
INTEC Video Systems, Inc.
Customer Service Department
23301 Vista Grande
Laguna Hills, CA 92653
Attn:RMA_____

Eastern U.S. and Canada:
INTEC Video Systems, Inc.
Customer Service Department
4256 State Route 51 North
Belle Vernon, PA 15012
Attn:RMA_____

Make sure to package your Car Vision® unit carefully to avoid any damage during shipping. If possible, use the original carton and packaging materials. Our warranty does not cover loss or damage in transit.

Product shipped to us without an RMA number may not be accepted or may result in a delay in service. Make sure your name, address and phone number appear somewhere on the shipping container or paperwork enclosed within.

You may also call to inquire about any installation issues or concerns.

Additional Information

Warranty

INTEC warrants the Car Vision® Camera, Model CVC240HXL and CVC240SHXL, when purchased new, to be free from defects in material and craftsmanship. INTEC will repair or replace, at INTEC's sole option and without charge, any part which under normal and proper use is found to be defective within the effective period of this warranty. The effective period of this warranty is eight (8) years from the original date of purchase from INTEC. This warranty is void and does not cover product that has been lost or damaged in shipment, subjected to misuse, abuse, tampering, improper installation, use on improper voltage or current, use contrary to operating instructions, or disassembly, repair, or alteration by anyone other than INTEC or an INTEC authorized service agent.

IN NO EVENT SHALL INTEC BE LIABLE FOR SPECIAL, INDIRECT, INCIDENTAL OR CONSEQUENTIAL DAMAGES, OR EXPENSES. THE SOLE LIABILITY OF INTEC SHALL BE DISCHARGED BY REPAIRING OR REPLACING ANY PART OR PARTS WHICH MAY PROVE DEFECTIVE UNDER NORMAL AND PROPER USE WITHIN THE CONDITIONS AND EFFECTIVE PERIOD OF THIS WARRANTY, PROVIDED THE PRODUCT IS RETURNED TO INTEC, DELIVERY PREPAID AND INSURED, IN ACCORDANCE WITH THE INSTRUCTIONS SET FORTH IN THE SERVICE INFORMATION SECTION OF THIS GUIDE.

THERE SHALL BE NO OTHER WARRANTIES, EXPRESSED OR IMPLIED, INCLUDING ANY IMPLIED WARRANTY OF MERCHANTABILITY OR FITNESS FOR A PARTICULAR PURPOSE OR ANY OTHER OBLIGATION ON THE PART OF INTEC.

This warranty gives you specific legal rights, and you may also have other rights that vary from state to state. You should contact the appropriate state agency to find out what these rights might be.

Return of the Owner Registration Card is not required for warranty coverage. However, it will insure that you are notified with product update information. It will also help INTEC to better serve you by answering some important marketing questions on the Card. Any information you provide on the Card is for INTEC's internal use only. Our customer list is not sold or given to any other organizations unless required under State or Federal laws.

Thank you for your business.

INTEC Offices

Headquarters

Western Regional Sales and Service

23301 Vista Grande
Laguna Hills, California 92653 USA

USA and Canada
Tel: 800-468-3254
Fax: 949-859-3178

International
Tel: 949-859-3800
Fax: 949-859-3178

Eastern Regional Sales and Service

4256 State Route 51 North
Belle Vernon, Pennsylvania 15012

USA and Canada
Tel: 800-522-5989
Fax: 724-929-6590

International
Tel: 724-929-5500
Fax: 724-929-6590
www.intecvideo.com

Owner Registration

Model CVC240(S)HXL

Name: _____

Address: _____

City: _____ State: _____ Zip: _____

Serial Number: _____
(Located on the back of the camera)

Purchased from: _____

Address: _____

City: _____ State: _____ Zip: _____

Date of Purchase: _____ Date of Installation: _____

Installed on what type of vehicle: Manufacturer: _____

Model: _____ Size (length): _____

Installed by: Manufacturer _____ Dealer _____
 Self _____ Other service shop _____

How did you hear about the INTEC Car Vision® System? INTEC _____ Distributor/Dealer _____

Trade Show _____ Magazine Ad _____ Article _____ Other equipment user _____ Friend _____

Previous experience _____ Web Search _____ Other _____

What industry magazines do you read? _____

What trade shows do you attend? _____

Why did you decide to purchase the Car Vision® System? _____

How can we improve our product or service? _____

Mail Registration to: INTEC Video Systems, Inc., 23301 Vista Grande, Laguna Hills, CA 92653. You may also fax it to us at (949) 859-3178 or complete it online by visiting www.intecvideo.com/registration.pdf